

Advanced Wheeler cap method for measuring the antenna efficiency

#Chihyun Cho¹, Hosung Choo², No-Weon Kang³, Jin-Seob Kang³

¹ Communication R&D Center, Samsung Thales

188 Gumi-dong, Bundang-gu, Seongnam-si 463-870, Korea, chihyun.cho@gmail.com

² School of Electronic and Electrical Engineering, Hongik University

72-1 Sangsu-dong, Mapo-gu, Seoul, 121-791, Korea

³ Division of Physical Metrology, Korea Research Institute of Standards and Science

267 Gajeong-ro, Yuseong-gu, Daejeon 305-340, Korea

1. Introduction

In 1959, Wheeler published the theory of the radiansphere, which is the boundary between the far and near field with a distance of $\lambda/2\pi$ from an antenna. The inside field of the radiansphere is mainly involved in the loss power and stored energy, while the outside field is concerned with the radiation power. Wheeler's theory is that the radiation power can be removed from the antenna without disturbing the loss power and stored energy when it is shielded by placing the conducting shell on the radiansphere [1]. The conventional Wheeler cap method predicts radiation efficiency by comparing the input resistances (or conductances) in free-space and in the cap [2]. This involves the assumption that the antenna under test (AUT) operates as a simple RLC circuit at the operating frequency. However, efficiency cannot be measured accurately by simply comparing input resistance (or conductances) when the AUT has a more complicated operating principle. To solve this problem, we applied the cascade parallel circuit [3] to the Wheeler cap method. This approach is superior to the conventional Wheeler cap, but it can be only applied to a microstrip patch with a probe feeding structure.

In this paper, a high-order transformer equivalent circuit model is proposed to generalize our previous work on measuring the efficiency of various antennas. In addition, a simple scheme to find the lumped element in the equivalent circuit using heuristic optimization is proposed. To confirm the proposed method, the efficiency of a quad-band microstrip antenna is measured; this shows good agreement with the simulation result, while the conventional Wheeler cap shows an unreliable result.

2. The advanced Wheeler cap method

2.1 The Wheeler cap concept based on a high-order circuit

When AUT has a complicated operating principle, it usually has multiple radiating modes. These modes are tightly linked, and the input resistance on those modes are highly dependent on the loss mechanism of AUT. In this case, the conventional Wheeler cap often shows unreliable results, since the efficiency is obtained by simply comparing the variations of the input resistance without considering the characteristics of the radiating modes.

In this paper, a high-order circuit model is employed to properly represent the characteristics of each mode and obtain more accurate efficiency measurement. If the equivalent circuit agrees well with the loss mechanism of AUT, it can represent the input impedance of AUT in free space, as well as with the conducting cap, by changing only the resistance values. The full circuit model can be completed by finding both the loss resistances and radiation resistances. Then, the efficiency can be obtained by calculating the power dissipation on each resistor as follows:

$$Eff = \frac{P_{rad}}{P_{rad} + P_{loss}} = \sum_{i=1}^N \frac{|I_i|^2 \times R_i^{rad}}{|I_i|^2 (R_i^{rad} + R_i^{loss})} \quad (1)$$

where I_i is the current in the i -th mesh, N is the number of meshes, and R_i^{rad} and R_i^{loss} are the radiation and loss resistors used in the circuit model, respectively.

2.2 Multi-transformer high-order circuit

The proposed transformer circuit model consists of one series RLC circuit for the input terminal, shown on the left side of Fig. 1, and several series RLC circuits that are connected with the input circuit by mutual coupling M_i . The impedance of each RLC circuit is defined as (2), and the total impedance of the equivalent circuit is determined as (3).

$$Z_i = R_i + j\omega L_i + \frac{1}{j\omega C_i}, \quad (i=1, 2, \dots, N) \quad (2)$$

$$Z_{in} = Z_1 + \frac{\omega^2 M_2^2}{Z_2} + \frac{\omega^2 M_3^2}{Z_3} + \dots + \frac{\omega^2 M_N^2}{Z_N} \quad (3)$$

The impedance Z_1 on the input terminal determines the gradual slope of the impedance curve, and the mutually connected circuits ($Z_2 \dots Z_N$) generate fluctuations on the impedance curve at their resonance frequencies. The strength of the fluctuation is determined by the amount of the mutual coupling M , and the number of required transformers is the same as the number of resonances in AUT. We use a heuristic optimization method to find the appropriate lumped circuit values. In fact, the heuristic optimization method usually provides inappropriate solution if the initial values are far from the global optimum. Thus, to obtain the global solution in a short time, we propose a methodology for determining the proper initial value.

First, the RLC values of lumped elements in the input terminal can be determined using the gradual slope in the frequency of the measured data, as shown in (4)–(6).

$$R_1 = (R_{meas.}(f_{start}) + R_{meas.}(f_{end})) / 2 \quad (4)$$

$$j\omega(f_{start})L_1 + \frac{1}{j\omega(f_{start})C_1} = X_{meas.}(f_{start}) \quad (5)$$

$$j\omega(f_{end})L_1 + \frac{1}{j\omega(f_{end})C_1} = X_{meas.}(f_{end}) \quad (6)$$

In these equations, f_{start} and f_{end} are the first and last frequency points in the measured data, respectively. Small impedance fluctuations on f_{start} and f_{end} are recommended to represent the gradual slope of the impedance curve accurately. Then, L_1 and C_1 can be found by solving (5) and (6), and R_1 is determined by averaging the resistances on f_{start} and f_{end} . Next, the lumped element values of the mutually connected series circuit are found using (7) – (9).

$$M_i = \sqrt{\frac{(R_{meas.}(f_i^{peak}) - R_1) \times R_i}{(2\pi f_i^{peak})^2}} \quad (7)$$

$$L_i = \frac{M_i^2 (2\pi f_i^{peak})}{(X_{meas.}(f_i^{peak}) - X_1(f_i^{peak}))} \quad (8)$$

$$C_i = \frac{1}{(2\pi f_i^{peak})^2 L_i}, \quad (i=2, 3, \dots, N) \quad (9)$$

In these equations, f_i^{peak} is the frequency where the peak value occurs in the fluctuation of the measured input resistance. X_i is the imaginary value of Z_i using L_i , C_i , and R_i from (4)–(6). Then, L_i and C_i are lumped values of the mutually connected i -th RLC series circuit and M_i is the strength of mutual coupling between the input terminal and the transformer.

3. Results

The efficiency of the quad-band microstrip antenna is measured to confirm the proposed method [4]. In the high-order transformer circuit, the four transformer and five series RLC circuits are used to represent quad resonances of patch. Invasive Weed Optimization (IWO) is applied to optimize the value of lumped elements in the circuit model with a proposed initial values setting procedure. This can achieve fast convergence time and stable performance with small tuning parameters such as a boundary condition, maximum velocity and initial weights in PSO [5]. In the optimization process, the RMS error between the impedances of AUT and the circuit model is used for the cost function, as follows:

$$Cost = \sqrt{\sum_{i=1}^m (Z_{circuit} - Z_{AUT})^2} / \sqrt{m} \quad (10)$$

The impedances of the equivalent circuit model optimized with IWO and AUT where in free-space are represented in Fig. 2. The RMS error in the entire frequency range is only 1.09 Ω . Fig. 3 shows the impedance of AUT shielded with the conducting cap. The additional resonances due to the conducting cap occur at 1.3 and 2.1 GHz. The cost function is evaluated, with the exception of these cavity modes, in the IWO optimization. The impedance of the optimized circuit is represented with a dashed line, and it has an RMS error of 1.14 Ω .

To build the complete circuit model, these two optimized circuits are compared, and the variation of resistance and capacitance are observed on R_i and C_i . The changes in the capacitances are due to the parasitic capacitance between the AUT and the conduction cap. However, if the parasitic capacitances are disregarded, the complete circuit can be built by separating R_i^{rad} and R_i^{loss} from R_i as summarized in Table 1.

Finally, the measured efficiency using the complete circuit is plotted in Fig. 4 with a solid line. In addition, the efficiency using commercial software and the conventional Wheeler cap are represented with the dash-dotted and dashed line, respectively. In the conventional Wheeler cap, the conductance comparison that is commonly used to measure the efficiency of microstrip antenna is applied. The result using the proposed method shows an accurate efficiency result in a wide frequency range (over 1:3.25 bandwidth) compared to the conventional Wheeler cap. This confirms that the proposed method can be applied to various antennas such as RFID tags, broadband monopoles, wideband patches, and circular polarization antennas.

4. Conclusions

In this paper, we proposed the advanced Wheeler cap method based on the equivalent circuit model. We also proposed the high-order transformer circuit for an equivalent circuit model and the methodology to determine initial values for the heuristic optimization. To confirm the proposed method, we measured the efficiency of a quad-band microstrip antenna, and this showed a good agreement with the simulation, while the conventional Wheeler cap showed an unreliable measurement result.

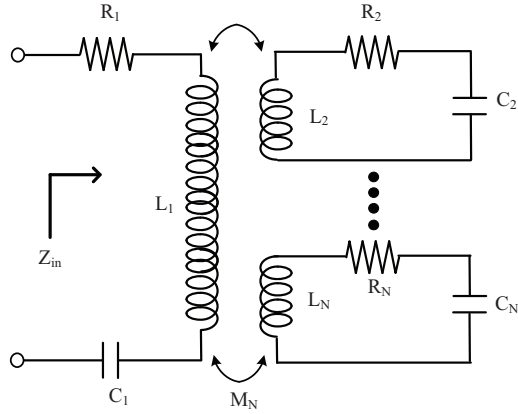

Figure 1: High-order transformer circuit

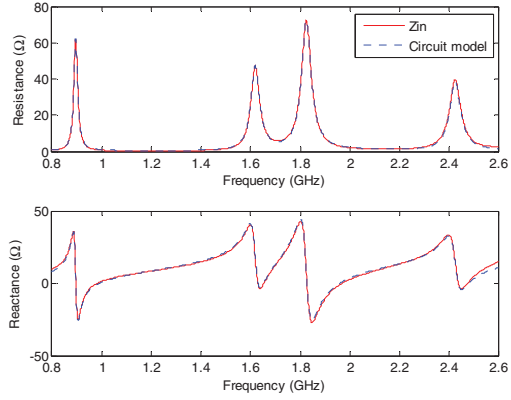

Figure 2: Impedance of circuit in free-space

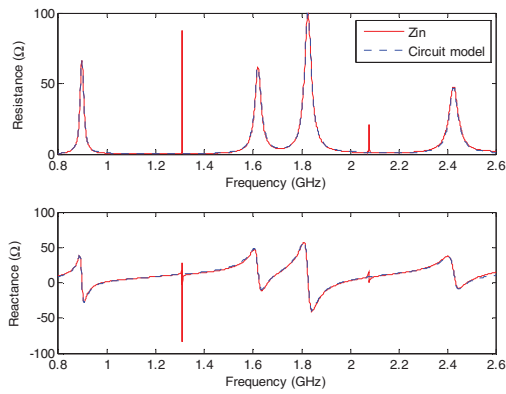

Figure 3: Impedance of circuit in the cap

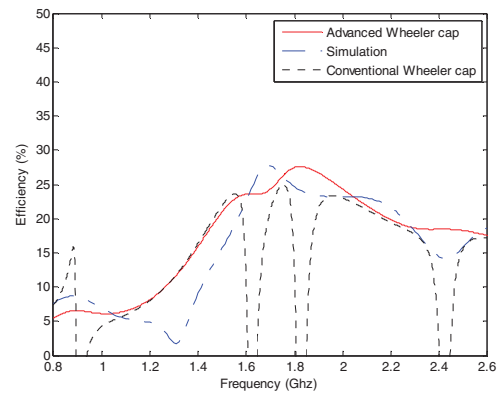

Figure 4: Efficiency of quad-band microstrip

Table 1: The values of lumped elements in a high-order transformer circuit

R_1^{rad}	0.0049 Ω	R_1^{loss}	0.18907 Ω	L_1	1.9551 nH	C_1	29.6574 pF
M_2	56.059 nH	M_3	34.4385 nH	M_4	25.9676 nH	M_5	21.3196 nH
R_2^{rad}	105.11	R_3^{rad}	628.48	R_4^{rad}	343.923	R_5^{rad}	510.5
R_2^{loss}	1501.74	R_3^{loss}	2022.41	R_4^{loss}	896.527	R_5^{loss}	2255.84
L_2	13.7207 μ H	L_3	9.9923 μ H	L_4	4.1727 μ H	L_5	8.4229 μ H
C_2	2.3025 fF	C_3	0.96851 fF	C_4	1.8260 fH	C_5	0.5123 fH

References

- [1] H. A. Wheeler, "The radiansphere around a small antenna", *Proc. IRE*, vol. 47, No. 8, pp. 1325-1331, 1959.
- [2] D. M. Pozar, B. Kaufman, "Comparison of three methods for the measurement of printed antenna efficiency", *IEEE Trans. Antennas Propag*, vol. 36, No. 1, pp. 136-139, 1988.
- [3] C. Cho, I. Park, H. Choo, "A Modified Wheeler Cap Method for Efficiency Measurements of Probe-Fed Patch Antennas With Multiple Resonances", *IEEE Trans. Antennas Propag*, vol. 58, No. 9, pp. 3074-3078, 2010.
- [4] H. Choo, H. Ling, "Design of Multiband Microstrip Antennas Using a Genetic Algorithm", *IEEE Microw. Wireless Compon. Lett.*, vol. 9, No. 9, pp. 345-347, 2002.
- [5] S. Karimkashi, A. A. Kishk, "Invasive Weed Optimization and its Features in Electromagnetics", *IEEE Trans. Antennas Propag*, vol. 58, No. 4, pp. 1269-1278, 2010.